

Development of a Master-Slave System for Active Endoscope Using a Multi-DOF Ultrasonic Motor

Kenjiro Takemura, Dai Harada and Takashi Maeno

Department of Mechanical Engineering

Keio University

3-14-1 Hiyoshi, Kohoku-ku, Yokohama 223-8522 JAPAN

E-mail : kenjiro@bea.hi-ho.ne.jp, haradai@aurora.dti.ne.jp, maeno@mech.keio.ac.jp

Abstract

Endoscopes for industrial and medical fields are expected to have multi degree-of-freedom (DOF) motions. A multi-DOF ultrasonic motor we developed consists of a spherical rotor and a bar-shaped stator, and the rotor rotates around three perpendicular axes using three natural vibration modes of the stator. In this study, a multi-DOF unilateral master-slave system for active endoscope using the multi-DOF ultrasonic motor is developed. The configurations of master and slave arms for active endoscope are similar, so that an operator can easily handle the master-slave system.

First, driving characteristics of the multi-DOF ultrasonic motor are measured in order to design the slave arm and its controller. Next, the master arm and the slave arm are designed. Then, the unilateral feedback controller for the master-slave system is developed. Finally, the motion control tests of rotor are conducted. As a result, the possibility of the endoscope is confirmed.

1. Introduction

Endoscopes are now widely used in fields of industry, medicine and so on. As the fields are extending, an expectations for active endoscopes are growing. Furthermore, a number of DOF for its motion is expected to become large. Because of the reasons, some active endoscopes are developed [1][2][3]. Some of them use general electromagnetic motors and wires to actuate their active joints [1]. Nevertheless, it is difficult to construct a small-sized multi-DOF active endoscope using the general electromagnetic motors, because they need many motors to conduct several-DOF motions and they also need reduction gears for each motor to obtain higher torque, which result in large total volumes and weights of the system. Because of this, active endoscopes using, so to say, "new actuators" are developed [2][3]. Such endoscopes as mentioned above uses single-DOF actuators to generate multi-DOF motions. On the other hand, there are also studies for multi-DOF actuators. Roth *et al.* proposed a three-DOF variable reluctance spherical wrist motor [4]. Yano developed a spherical stepping motor [5]. These motors use the principle of the electromagnetic motor, and therefore, geometries of the motors are complicated.

On the other hand, ultrasonic motors have excellent characteristics such as high torque at low speed, high

stationary limiting torque, absence of electromagnetic radiation and simplicity of design. Therefore, multi-DOF actuators using the principle of ultrasonic motors are proposed as follows.

Bansevicus developed a piezoelectric multi-DOF actuator [6] consists of a cylindrical stator (vibrator) and a spherical rotor. Amano *et al.* developed a multi-DOF ultrasonic actuator [7] in which a spherical rotor rotates around three perpendicular axes. Toyama constructed a spherical ultrasonic motor [8] consists of three ring-shaped stators and a spherical rotor. Sasae *et al.* developed a spherical actuator [9] where a three-DOF motion unit is constructed using truss arranged PZTs.

Although the actuators [6]-[9] can generate multi-DOF motions of rotors, they cannot be used in place of multi-DOF motion units consists of general electromagnetic motors because of their small output torque, low controllability and non-simplicity of design. In order to solve these issues, the geometries of multi-DOF ultrasonic motors must be designed precisely.

The authors have developed a new type of ultrasonic motor capable of generating multi-DOF motion [10]. The multi-DOF ultrasonic motor generates multi-DOF rotation of a spherical rotor using three natural vibration modes of a bar-shaped stator. In other words, the multi-DOF ultrasonic motor can generate the motion similar to the human wrist only by one stator.

Hence, if the several multi-DOF ultrasonic motors were connected in series, an extremely high-performance novel endoscope can be constructed. The high-performance endoscope is superior to the former ones with respect to its number of DOF of motion and its scale. Even if only one multi-DOF ultrasonic motor is used to construct the endoscope, it has a great performance because it can generate the multi-DOF motion only by a single actuator. In this study, a master-slave system for active endoscope using the multi-DOF ultrasonic motor is developed.

In the present paper, the driving principle, configuration and driving characteristics of the multi-DOF ultrasonic motor are briefly described in chapter 2. Configurations of master and slave arms for endoscope, a controller for the master-slave system and experimental results of the motion control tests are shown in chapter 3. Then in chapter 4, the conclusions of this study are described.

2. Multi-DOF Ultrasonic Motor

2.1. Driving Principle

The multi-DOF ultrasonic motor we developed consists of a bar-shaped stator and a spherical rotor. The spherical rotor rotates around three perpendicular axes by combining a first longitudinal vibration mode and two second bending vibration modes of the bar-shaped stator. Figure 1 shows the driving principle of the multi-DOF ultrasonic motor. The x -, y - and z -coordinate used in the present paper are defined as shown in Fig. 1.

Fig. 1 (a) shows the case when the rotor rotates around the z -axis. When the second bending modes in the z - x and the y - z plane, illustrated in (i)(iii) and (ii)(iv), respectively, are combined at a phase difference of 90 deg, points on the stator head draw elliptic loci around the z -axis. Then, the rotor, in contact with the stator head, rotates around the z -axis by frictional force. Fig. 1 (b) shows the case when the rotor rotates around the x -axis. When the first longitudinal mode along the z -axis and the second bending mode in the y - z plane, illustrated in (i)(iii) and (ii)(iv), respectively, are combined at a phase difference of 90 deg, points on the stator head draw elliptic loci around the x -axis. Then, the rotor rotates around the x -axis by frictional force. In case when the rotor rotates around the y -axis, the first longitudinal modes along the z -axis and the second bending mode in the z - x plane are combined in the same way as Fig. 1 (b).

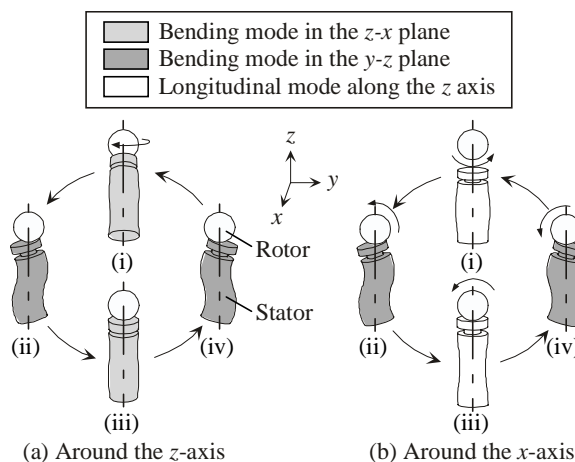

Fig. 1 Driving principle of a multi-DOF ultrasonic motor

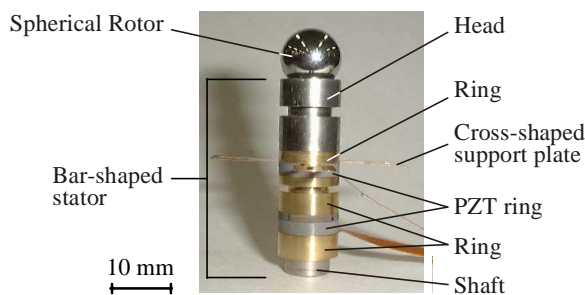

Fig. 2 The multi-DOF ultrasonic motor

An important thing to be mentioned is that the natural frequencies of the first longitudinal mode and the second bending modes must almost correspond.

2.2. Geometry

The natural frequencies of the first longitudinal and the second bending vibration modes must correspond as mentioned in section 2.1. Hence, the geometry of the bar-shaped stator was designed using finite element analysis.

Figure 2 shows the multi-DOF ultrasonic motor we developed in our previous study, whose diameter and height of the stator are 10 and 31.85 mm, respectively. The spherical rotor is made of stainless steel. The bar-shaped stator consists of brass head and rings, piezoelectric ceramic rings and a stainless steel shaft. The shaft is screwed up into the head in order to construct the stator as Langevin type vibrator. The piezoelectric ceramic rings are used to excite both the first longitudinal mode and the second bending modes of the bar-shaped stator. A cross-shaped phosphor bronze plate is fixed onto a pedestal, not illustrated in Fig. 2, in order to support the stator.

The natural frequencies of the first longitudinal mode and the second bending modes of the stator almost correspond. The experimental natural frequencies are around 40 kHz.

2.3. Driving Characteristics

The spherical rotor of multi-DOF ultrasonic motor rotates around three perpendicular axes in theory as mentioned in section 2.1. In order to develop a master-slave system using the multi-DOF ultrasonic motor, its driving characteristics must be clarified.

In case of the multi-DOF ultrasonic motor, three natural vibration modes are excited on the bar-shaped stator. So, there need three alternating inputs. Concerning the rotation around each driving axis, variable input parameters for the multi-DOF ultrasonic motor are just three, which are frequency, voltage and time phase, provided that the total number of variable parameters add up to nine when considering the rotations around three axes; i.e. three frequencies, three voltages and three time phases. In this section, measured relationships between the each input parameter and rotational speed around the x -axis are shown. Then, a relationship between the torque and rotational speed is shown.

(a) Relationships between Each Input Parameter and Rotational Speed

The measured relationships between the each input parameter and rotational speed are shown in Figure 3. The positive and negative values of the rotational speed correspond to the rotational direction of the rotor, CW and CCW, respectively. Fig. 3 (a), (b) and (c) are when the frequency, voltage and time phase are changed, respectively. In case of Fig. 3 (b), only the voltage of input signal for the second bending mode was changed because the longitudinal vibration is mainly used as a clutch and does not provide much driving force. In case of Fig. 3 (c), only the phase of input signal for the second bending mode

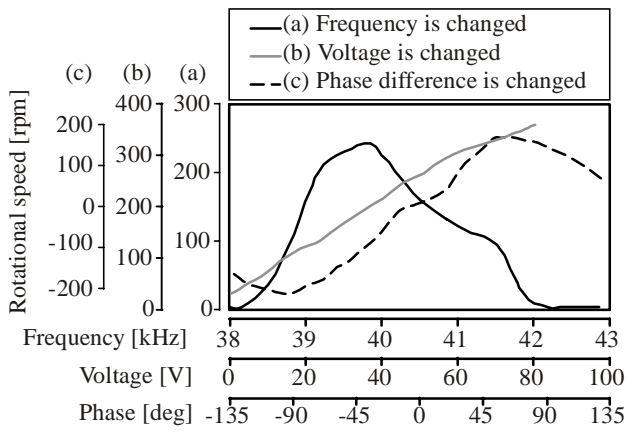

Fig. 3 Motor characteristics

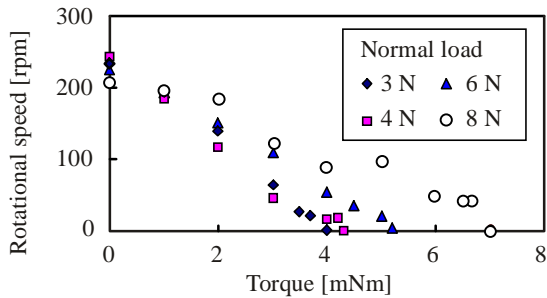

Fig. 4 Relationship between torque and rotational speed

Table 1 Basic input for the multi-DOF ultrasonic motor

	Longitudinal mode	Bending mode in z-x plane
Voltage [V]	10	20
Phase [deg]	0	90
Freq. [kHz]	39.5	

was changed and that for the first longitudinal mode was fixed at 0 deg. The basic inputs for the multi-DOF ultrasonic motor are shown in Table 1.

It is seen from Fig. 3 that the rotational speed can be varied by changing the values of each input parameter. However, the rotational speeds vary non-linearly when the frequency and time phase are changed. In case of Fig. 3 (b), the rotor does not stop when the voltage is 0 V, because the contact points between the rotor and stator do not vibrate exactly along the z-axis when the first longitudinal mode is only excited on the stator. Moreover, it can be seen that the rotational direction of the rotor can be reversed only by changing the sign of the time phase.

(b) Relationship between Torque and Rotational Speed

Figure 4 shows the measured relationship between the torque and rotational speed when the normal load between the rotor and stator is varied. The basic inputs are the same as those in Table 1.

It can be seen from Fig. 4 that the rotational speed decreases as the torque increases, and that the maximum torque increases as the normal load between the rotor and stator increases. The maximum values of the rotational

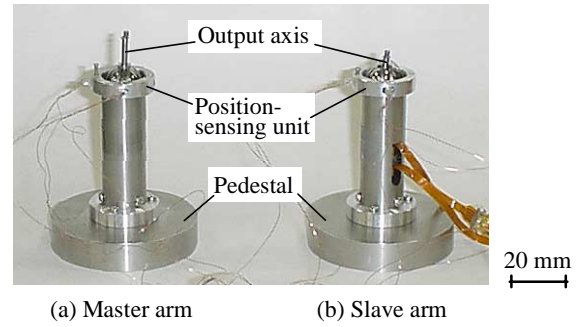

Fig. 5 Master and slave arms for active endoscope

speed and the output torque under the experimented conditions are about 250 rpm and 7 mNm, respectively. The estimated rotational speed, calculated using the result of finite element analysis is about 400 rpm, and the estimated torque, calculated from the experimented conditions, is 20 mNm. The differences between the estimated and measured values are due to the followings.

The estimated values are calculated under the assumption that there are no stiffness and no slip state at the contact interface on the stator. However, at the contact interface, the rotor actually declines with respect to the stator, and there can be seen the stick/slip state. The difference causes the declinations as mentioned above [11][12]. In addition, the coefficient of friction under the ultrasonic vibration becomes lower than that under normal contact condition [13].

3. Master-Slave System for Active Endoscope

3.1. Configurations of Master and Slave Arms

A multi-DOF master arm and a multi-DOF slave arm for active endoscope are designed. The bar-shaped stator and the spherical rotor of multi-DOF ultrasonic motor are located in the slave arm. Then, the same sized spherical rotor, as one for the multi-DOF ultrasonic motor, is located in the master arm, too. The produced master and slave arms are shown in Figure 5. The diameters and heights of both the cylindrical master and slave arms are 15 mm and 44.5 mm, respectively. It is required for the medical endoscope that its diameter is 15 mm or less in order to make the endoscope inserted into human body through trocar. The slave arm is designed to meet the requirement.

Figure 6 (a) shows the configuration of the master arm. The master arm mainly consists of a position-sensing unit, spherical rotor, rotor/stator contact unit and cylindrical outer cases. The position-sensing unit is shown in Figure 7. The unit has two potentiometers and two arch-shaped rails. Using the unit, angular positions of the spherical rotor around the x- and y-axis can be measured. The unit is located at the top of the outer case. The rotor/stator contact unit in detail is shown in Figure 8. The spherical rotor is put onto a resin ring, in which there is a magnet disk. The normal load between the rotor/stator can be adjusted moving the magnet's position determined by a screw.

Figure 6 (b) shows the construction of the slave arm. The slave arm mainly consists of a position-sensing unit, multi-DOF ultrasonic motor and cylindrical outer cases.

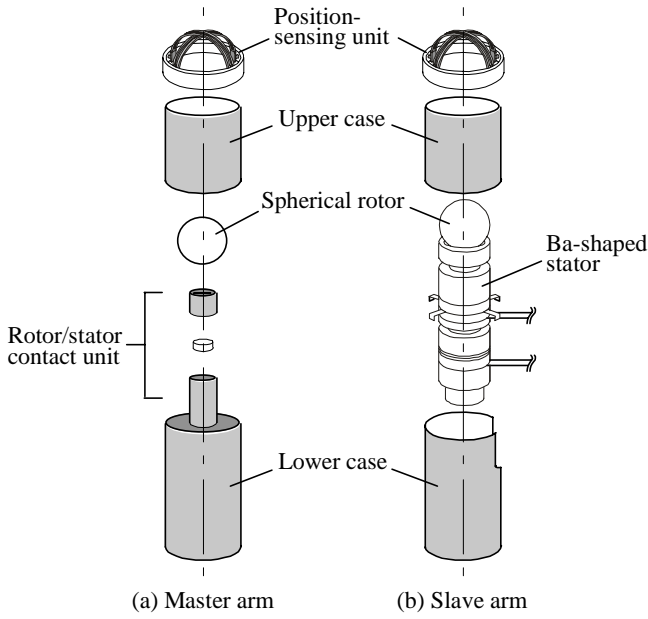

Fig. 6 Configurations of arms

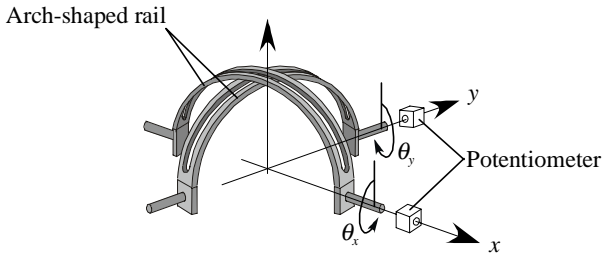

Fig. 7 Position sensing unit

The multi-DOF ultrasonic motor is supported by the cross-shaped plate which is held between the upper and lower cylindrical outer cases. The same position-sensing unit as Fig. 7 is located at the top of the outer case, too.

As you can see from Fig. 5 and Fig. 6, the configurations of master and slave arms, especially for the position sensing unit and spherical rotor, are quite similar, so that they can be easily operated and their postures are easily identified.

3.2. Controller for Master-Slave System

The master-slave system is constructed as shown in Figure 9. The potentiometers of master and slave arms are connected to a personal computer through A/D converter. The three input signals for the multi-DOF ultrasonic motor are generated at a function generator and phase shifters, according to the declinations of angular positions that are calculated in the personal computer.

A controller for the master-slave system is constructed as follows.

First, we determined the operating parameter for the multi-DOF ultrasonic motor. It can be seen from Fig. 3 that all the parameters of input signal seem to have potentials to be an operating parameter for the multi-DOF ultrasonic motor. Although the frequencies are usually used as operating parameters in case of the late single-DOF

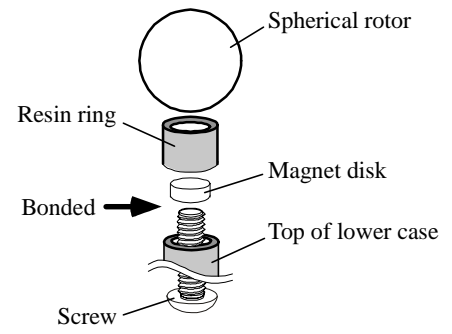

Fig. 8 Rotor/stator contact unit

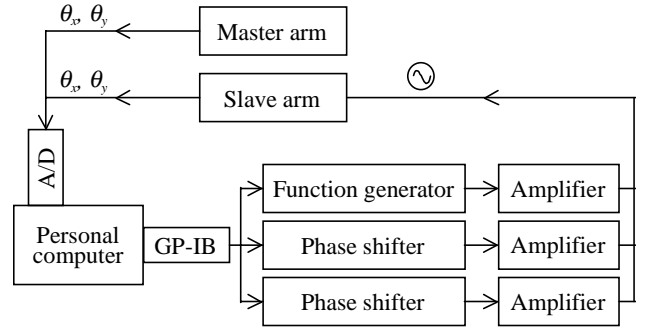

Fig. 9 Master-slave system

ultrasonic motors, we adopt the voltage as an operating parameter because of particular requirements for the multi-DOF ultrasonic motor: i.e. the rotational speeds around each axis must be controlled independently and there must not be a inappropriate mixture of vibration modes. However, the rotational directions of the spherical rotor around each axis are controlled by the time phases of bending vibrations.

Second, the control algorithm for the master-slave system is proposed. The proportional control method with bias is used to control the voltages of the input signals as Equation (1).

$$V_{ben} = K_p \cdot |\theta_{sla} - \theta_{mas}| + \varepsilon \quad (1)$$

where, V_{ben} is the voltage of input signals for bending vibrations, K_p is the proportional feedback gain, θ_{sla} and θ_{mas} are the angular positions of spherical rotor for the slave and master arms, respectively, and ε is the bias. The reason why we adopt the bias is as follows. In case of ultrasonic motors, the rotors does not be rotated when the amplitude of vibrations are too small, because there is a normal load between the rotor and stator and is the particular stiffness at their contact point. The time phases of the input signals are determined as Equation (2).

$$\phi_{ben} = \begin{cases} \pi/2 & (\theta_{sla} \geq \theta_{mas}) \\ -\pi/2 & (\theta_{sla} \leq \theta_{mas}) \end{cases} \quad (2)$$

where, ϕ_{ben} is the time phase of input signals for bending vibrations.

Then, the controller for master-slave system is constructed using the algorithm mentioned above by use of Microsoft Visual C++.

3.3. Motion Control Tests

Here show results for step response of the ultrasonic motor and master-slave control tests. Both results are obtained using the proportional controller.

(a) Step response

Step response of the spherical rotor around the x -axis is tested first. A desired position is set at 0 deg, and initial positions are -40, -30, -20, -10, 10, 20, 30 and 40 deg. Figure 10 shows the results for step responses using the proportional controller when both the proportional feedback gain and bias are 0.1. Other experimental conditions follow those of Table 1.

It can be seen from Fig. 10 that the angular position of rotor is successfully controlled to the desired one using the proportional controller when the proportional feedback gain and bias are adjusted to suitable ones.

(b) Master-slave control

Motion control tests of the master-slave system are

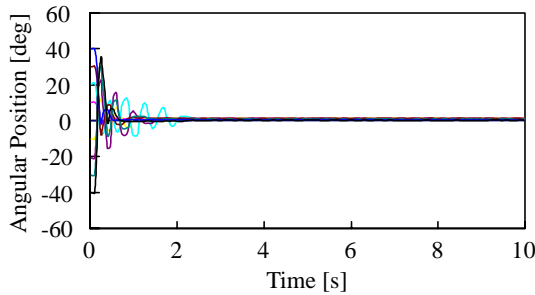

Fig. 10 Result for step response

Table 2 Experimental conditions

Experiment No.	Feedback gain K_p	Bias ε	Freq. [kHz]
(1)	0.10	0.00	39.11
(2)	0.10	0.30	39.11
(3)	0.15	0.25	39.11

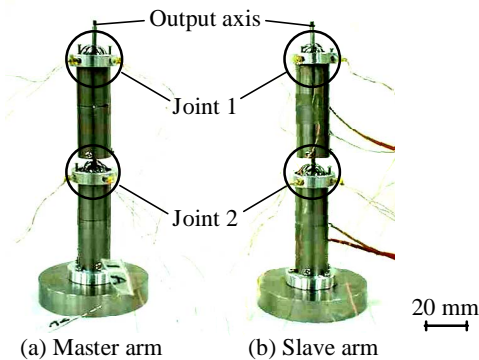

Fig. 11 Master and slave arms with two joints

conducted next. The experimental conditions are shown in Table 2. The experiment (1) is a control of angular position of the rotor only around the x -axis using the proportional controller. Then, angular positions around the x - and y -axis are controlled in parallel in the experiment (2). Finally, in the experiment (3), two master arms and two slave arms are connected in series as shown in Figure 11. Then, angular positions of two rotors of slave arms are controlled to those of master arms.

Figure 12 (a) shows the result for the experiment (1). It can be seen from Fig. 11 (a) that the angular position of the slave arm around the x -axis follows that of the master arm, although there remain some declinations of angular position.

Figure 12 (b) shows the result for the experiment (2). The angular positions of the slave arm around the x - and y -axis are controlled simultaneously to those of the master arm, which can be seen in Fig. 12 (b).

Figure 13 shows the result for the experiment (3). Fig. 13 shows the control characteristics for joint 2 (cf. Fig. 11). It can be seen from Fig. 13 that the angular positions of slave arm around the x - and y -axis follow those of master

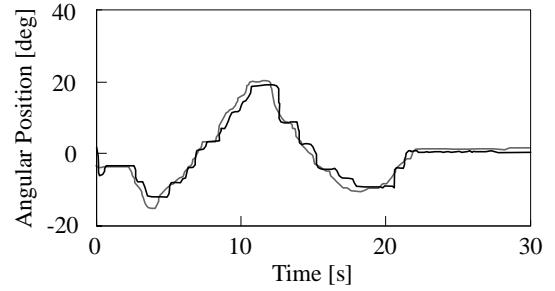

(a) around the x -axis

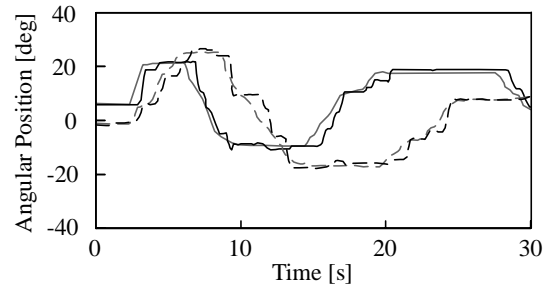

(b) around the x - and y -axis

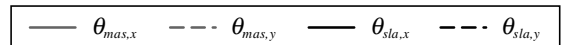

Fig. 12 Result for master-slave control with one joint

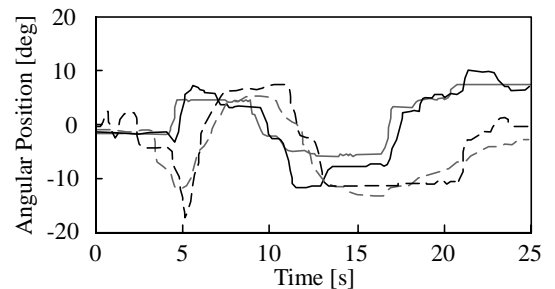

Fig. 13 Result for master-slave control with two joints

arm using the proposed controller.

The values of proportional feedback gains and biases for the above experiments differ each other, because there are differences of load torques and vibrating characteristics for each experimental state. Although the rotor positions are controlled using the proposed controller, the vibrations of positions and the time delay for the slave arm with respect to master arm can be seen in the Fig. 12 and Fig. 13. It is due to the rough sampling rate for the prototype system. However, it can easily be improved if an exclusive electronic circuit is produced for the controller.

4. Conclusion

The master-slave system for active endoscope using the multi-DOF ultrasonic motor is developed. The master and slave arms for active endoscope have two joints to generate four DOF motions.

First, the master-slave system whose master and slave arms have similar configurations is constructed. The similar configurations of the master and slave arms are intended to provide an easy operation. Then, the controller for the master-slave system is developed considering the characteristics of the multi-DOF ultrasonic motor. Finally, the motion control tests of the master-slave system are conducted. The position of spherical rotor for the slave arm successfully follows that for the master arm using the developed controller.

A CCD camera should be mounted in the spherical rotor for the slave arm in our future study. Future study is also needed to construct a master-slave system which has a number of multi-DOF ultrasonic motors in series.

5. References

- [1] K. Ikuta, H. Higashikawa and K. Ogata, "Study on Hyper Endoscope for Remote Minimal Inversive Surgery," *Proc. 17th RSJ*, No. 2, pp. 675-676, 1999. [in Japanese]
- [2] S. Guo, T. Fukuda, F. Arai, K. Oguro, M. Negoro and T. Nakamura, "Micro Active Guide Wire Catheter System – Characteristic Evaluation, Electrical Model and Operability Evaluation of Micro Active Catheter -," *Proc. IEEE 6th Int. Symp. Micro Machine and Human Science*, pp. 131-136, 1995.
- [3] S. Maeda, O. Tohyama and H. Ito, "Micro Actuator with Shape Memory Alloy (SMA) Coil Spring and their Application to Active Fiberscopes," *IEICE Trans. Electronic*, Vol. E80-C, No. 2, pp. 226-231, 1997.
- [4] R. Roth, and K-M. Lee, "Design Optimization of a Three Degrees-of-Freedom Variable Reluctance Spherical Wrist Motor," *Trans. ASME J. Engineering for Industry*, Vol. 117, pp. 378-388, 1995.
- [5] T. Yano, T. Suzuki, M. Sonoda and M. Kaneko, "Basic Characteristics of the Developed Spherical Stepping Motor," *Proc. 1999 IEEE/RSJ Int. Conf. Intelligent Robots and Systems*, Vol. 3, pp. 1393-1398, 1999.
- [6] R. Bansevicius, "Piezoelectric Multi-degree of Freedom Actuators/Sensors," *Proc. 3rd Int. Conf. Motion and Vibration Control*, pp. K9-K15, 1996.
- [7] T. Amano, T. Ishii, K. Nakamura and S. Ueha, "An Ultrasonic Actuator with Multi-Degree of Freedom using Bending and Longitudinal Vibrations of a Single Stator," *Proc. IEEE Int. Ultrasonics Symp.*, pp.667-670, 1998.
- [8] S. Toyama, S. Sugitani, G. Zhang, Y. Miyatani and K. Nakamura, "Multi degree of freedom Spherical Ultrasonic Motor," *Proc. IEEE Int. Conf. Robotics and Automation*, pp. 2935-2940, 1995.
- [9] K. Sasae, K. Ioi, Y. Ohtsuki and Y. Kurosaki, "Development of a Small Actuator with Three Degrees of Rotational Freedom (3rd report)," *J. Japan Society of Precision Engineering*, Vol. 62, No. 4, pp. 599-603, 1996. [in Japanese]
- [10] K. Takemura and T. Maeno, "Characteristics of an Ultrasonic Motor Capable of Generating a Multi-Degrees of Freedom Motion," *Proc. IEEE Int. Conf. Robotics and Automation*, pp. 3660-3665, 2000.
- [11] T. Maeno, T. Tsukimoto and A. Miyake, "Finite Element Analysis of the Rotor/Stator Contact in Ring-Type Ultrasonic Motor," *IEEE Trans. Ultrasonic Ferroelectrics and Frequency Control*, Vol. 39, No. 6, pp. 668-674, 1992.
- [12] T. Maeno, "Contact analysis of traveling wave type ultrasonic motor considering stick/slip condition," *J. the Acoustical Society of Japan*, Vol. 54, No. 4, pp. 305-311, 1998. [in Japanese]
- [13] H. Kanazawa, T. Tsukimoto, T. Maeno and A. Miyake, "Tribology of Ultrasonic Motors," *Tribologist*, Vol. 38, No. 3, pp. 21-26, 1993. [in Japanese]